



HT3000 Series – HT3328

High-Efficiency, IoT-Enabled, External MOSFET Dual-Buck DC-DC Controller with Selectable 150kHz/250kHz/350kHz Frequency

APPLICATION

- IoT (Internet of Things) Smart Home Appliance
- Mobile apps controllable DC source
- Automotive ADAS/LED Power Supply
- LCD Monitor Power Supply
- Wireless Router Power Supply
- Remote Power Management
 - Power Scheduler
 - CC-CV
- Low EMI Application (Patent Pending)

GENERAL DESCRIPTION

HT3328 is a high efficiency, dual-channel, Internet of Things (IoT) enabled, synchronous step-down switching controller designed for high-power applications.

HT3328 consists of an I²C interface to connect with other wireless communication modules (e.g. Bluetooth/Wi-Fi); hence it allows ON/OFF, output voltage and current limit control using mobile apps. As a result, HT3328 enhances productivity and efficiency by enabling remote power management of various IoT devices at homes, office buildings, automobiles, and factories, etc.

HT3328 allows a wide input voltage range from 7V to 36V, and provides a wide range of output. It can also deliver up to 100W or higher with appropriate FETs at each channel. It also provides selectable switching frequency for circuit design with different size of inductor or capacitor at high conversion efficiency.

HT3328 has soft start function, which prevent the inrush current at startup from affecting the stability of the input power. On the protection side, it has a variety of protections for both input and output against over voltage, short circuit or under voltage conditions (see Multi-Protection section).

FEATURES

Internet of Things (IoT) Enable function

- ON/OFF control
- Programmable using I²C serial interface
- Wireless connection with mobile apps

A sample IoT function is illustrated below flowchart:



Dual-Channel Synchronous Buck Controller

- Wide input voltage range: 7V to 36V
- Dual Channel with independent outputs
- Selectable switching frequency at 150kHz, 250kHz and 350kHz
- Support Constant Voltage and Current Limit Mode
- High Power output 60W per channel
- Soft-start function

Multi-Protection

- Input under-voltage lockout (UVLO)
- Output over-voltage protection (OVP)
- Output short-circuits protection (SCP)
- Over-temperature protection (OTP)

Output Protection

The Output Under-voltage Lockout threshold and the Output Over-voltage Protection are set at $V_{OUT} * 60\%$ and $V_{OUT} * 118\%$. Once Output UVLO or OVP is triggered, the specific channel stops the gate driver, reset and enter hiccup mode.

Soft Start

HT3000 series employs an internal soft start in the buck converter to prevent large inrush current and overshoots of V_{OUT} . The soft start time is 8ms in the design.

Programmable Output by I²C Serial Interface

A wireless communication module such as ESP8266 (master) can access HT3328 (slave) internal registers through the SCL and SDA pins. The master can program HT3328 power output by writing hex data to the registers. This I²C serial interface is enabled by setting the EN pins voltage greater than 12V (max $V_{en} = 36V$).

The I²C slave settings, register descriptions and hex data write operation are listed as below tables:

I²C Slave Settings

Support SCL frequency	Standard mode = 100K Hz Fast mode = 400K Hz
Device ID	28h (7 bits)
External Pull up	$R_{pull-up} = 1K \text{ ohm}$

Register Descriptions

Name and Addr	Bit	Bits Description
PROG_CV1, 0x00	<7:0>	Set constant voltage [†] at Channel 1
PROG_CC1, 0x01	<5:0>	Set current limit at Channel 1
PROG_CV2, 0x02	<7:0>	Set constant voltage at Channel 2
PROG_CC2, 0x03	<5:0>	Set current limit at Channel 2
Enable register, 0x07	<2:0>	Set the bits as 010 to enable Program Mode
ON/OFF Register, 0x08	<1> <0>	Set 1 shutdown channel 2 Set 1 shutdown channel 1

[†] The hex data for setting constant voltage and current limit is provided in the Appendix.

Hex data write operation

- Master Controls SDA Line
- Slave Controls SDA Line

Write to One Register in a Device

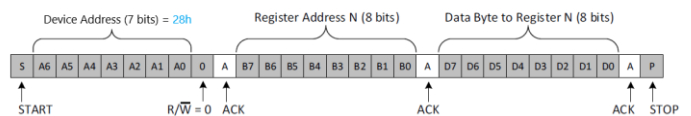

The register write operation can be implemented by Arduino I²C Wire Library easily.

Device Information

Part Number	Package	Dimensions (mm)
HT3328	WQFN32	5.0 x 5.0 x 0.75

Block Diagram

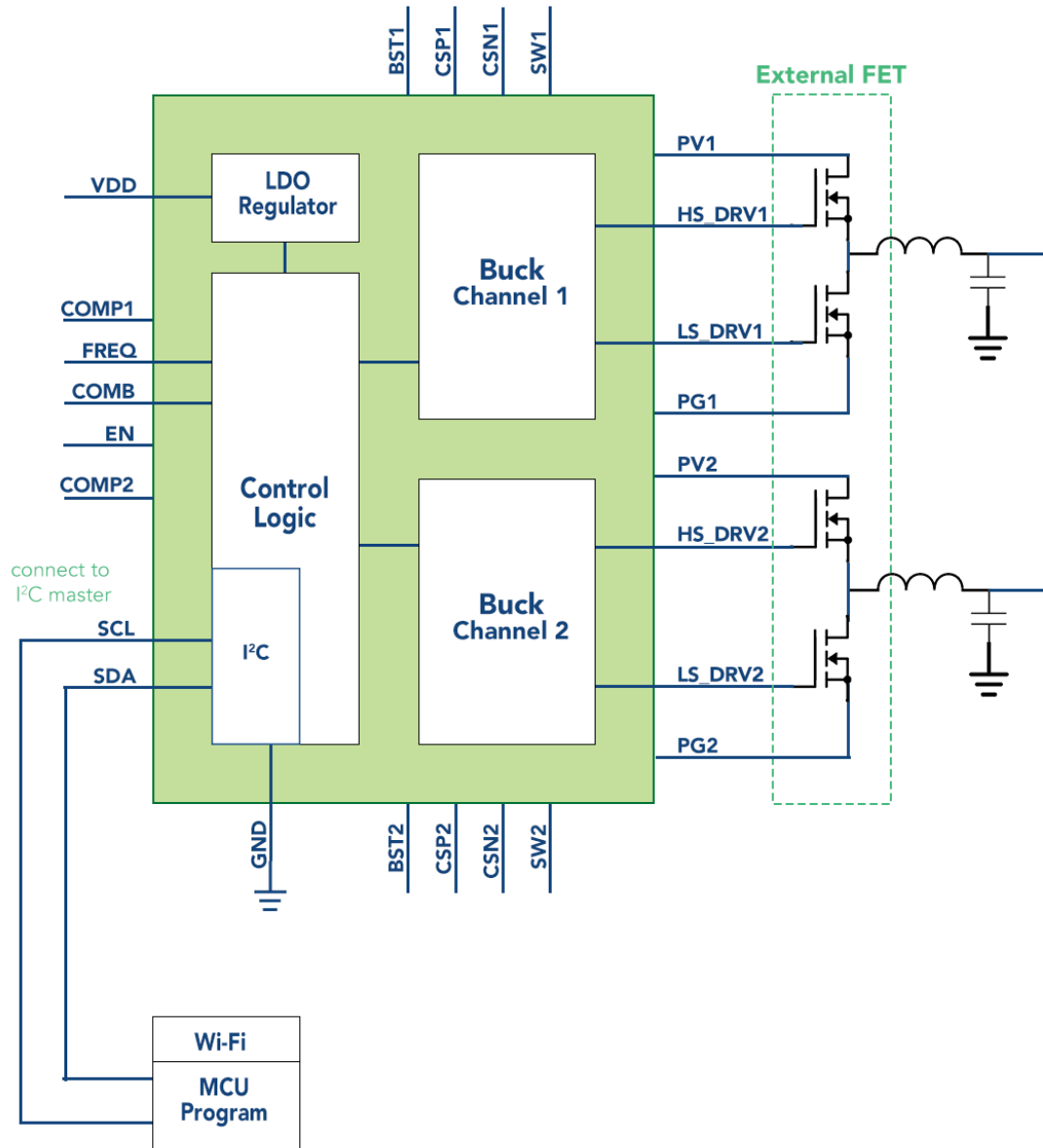

Fig. 1 - HT3328 Block Diagram

Absolute Maximum Rating

PV1, PV2, SW1, SW2, EN, BST1, BST2	-0.3V to 40V
CSP1, CSN1, CSP2, CSN2	-0.3V to 22V
VDD, COMP1, COMP2, SCL, SDA, FREQ	-0.3V to 6V
Operating Temperature Range	-40°C to 85°C
Maximum Junction Temperature	125°C
Storage Temperature Range	-65°C to 125°C
Soldering Temperature	300°C

Electrical Characteristics ($V_{IN}=8V$, $T_A=25^\circ C$ unless specified)

Parameters	Symbol	Test Conditions	Rating			Unit
			MIN	TYP	MAX	
Input Characteristics						
Operating Input Supply Voltage	V_{IN}		7		36	V
EN Thershold	V_{EN}			1.3 5		V
EN Hysteresis	V_{ENHYS}			110		m
Quiescent Current	I_Q			25		mA
Output Characteristics						
Output Voltage Range	V_{OUT}	$V_{IN}=24V$	3.6		20	V
Cycle-by-cycle Current Limit	I_{OCP}			6		A
Output Current Limit	I_{LIMIT_FB}	$R_{SENSE} = 10m\Omega$		3.3		A
Reference Voltage						
Output Voltage Reference	V_{FB}	Measured at FB1, FB2		1		V
Regulator Reference	VDD	Measured at VDD		5.3		V
Switching Characteristics						
Switching Frequency	f_{sw}	FREQ=Z		150		kHz
		FREQ=L		250		kHz
		FREQ=H		350		kHz
Minimum Off-Time	$t_{OFF, Min}$			80		ns
Output control by PROG (For both channel1 and channel2)						
Single Channel Output Voltage (PROG)	V_{OUT_PROG}	$V_{IN}=24V$, DAC_CV = 0.5V		5		V
		$V_{IN}=24V$, DAC_CV = 0.9V		9		V
		$V_{IN}=24V$, DAC_CV = 1.2V		12		V
		$V_{IN}=24V$, DAC_CV = 2V		20		V
	V_{STEP_PROG}	DAC_CV step		100		mV
Single Channel Output Current (PROG)	I_{OUT_PROG}	$R_{SENSE} = 10m\Omega$, DAC_CC = 1.2V		3.3		A
		$R_{SENSE} = 10m\Omega$, DAC_CC = 0.8V		2.1		A
		$R_{SENSE} = 10m\Omega$, DAC_CC = 0.6V		1.6		A
		$R_{SENSE} = 10m\Omega$, DAC_CC = 0.4V		1		A

Input Under-voltage Lockout Protection						
Input Under-Voltage Lockout Protection Lower Threshold	V _{UVLO_L}	Measured V _{UVLO} falling		0.40		V
Input Under-Voltage Lockout Protection Upper Threshold	V _{UVLO_U}	Measured V _{UVLO} rising		0.44		V
Output Over-voltage Protection						
Over-Voltage Protection – Channel 1	V _{OVP, CH1}	Measured VS1 when rising		2.40		V
Over-Voltage Protection – Channel 2	V _{OVP, CH2}	Measured VS2 when rising		2.40		V
Short Circuit Protection						
Short Circuit Protection – Channel 1	V _{SCP, CH1}	Measured V _{CSP1-CSN1} rising		50		mV
Short Circuit Protection – Channel 2	V _{SCP, CH2}	Measured V _{CSP2-CSN2} rising		50		mV
Over-Temperature Protection						
Internal Over-Temperature Protection Upper Threshold	T _{OTP_INT, U}	Surface Temperature Rising		125.0		°C
Internal Over-Temperature Protection Lower Threshold	T _{OTP_INT, L}	Surface Temperature Falling		105.0		°C
Digital Output Pins						
Digital Output High Voltage	VOH	Maximum Sink Current = 12mA	0.8 × VDD			V
Digital Output Low Voltage	VOL	Maximum Sink Current = 12mA			0.1 × VDD	V

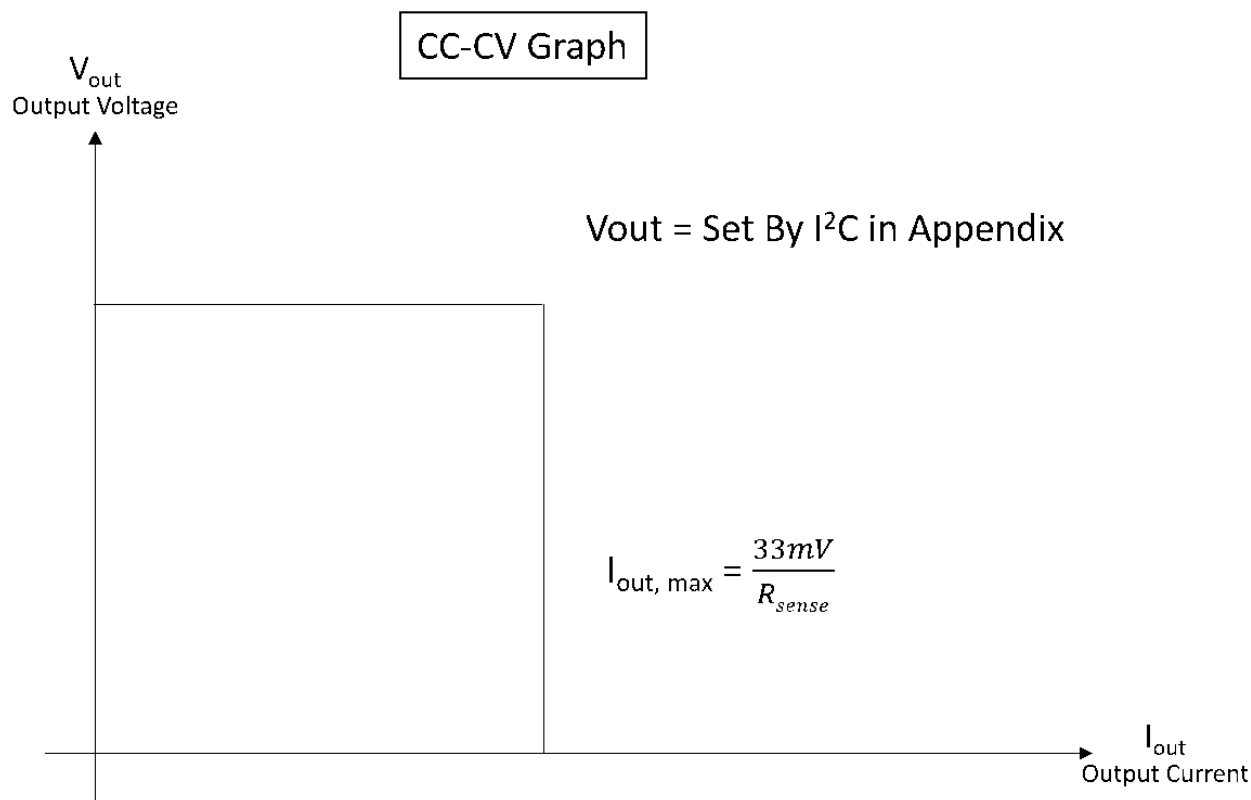

Fig.2 CC-CV graph

Pin Configuration

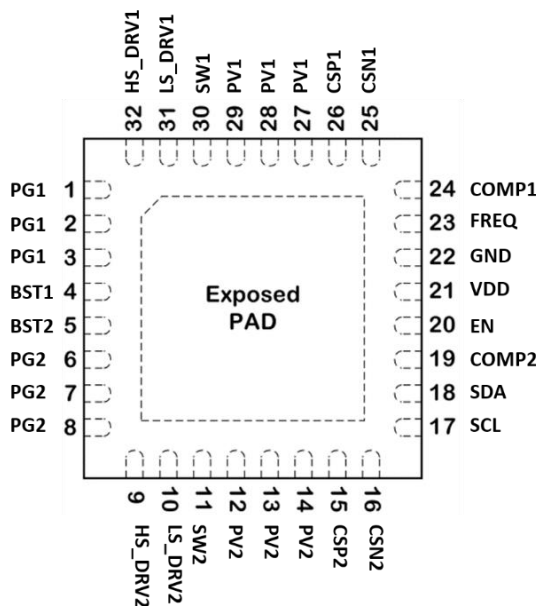

Fig. 3 32-pin QFN, 5x5 mm², 0.5mm pitch TOP VIEW

Pin Functions

HT3328 package: QFN32 (5mmx5mm)

Pin	Name	Description	Pin	Name	Description
1	PG1	Power Ground Channel 1	17	SCL	I ² C Clock
2	PG1	Power Ground Channel 1	18	SDA	I ² C Data
3	PG1	Power Ground Channel 1	19	COMP2	Compensation Pin 2
4	BST1	High Side Power Channel 1	20	EN	Chip Enable
5	BST2	High Side Power Channel 2	21	VDD	VDD Regulator
6	PG2	Power Ground Channel 2	22	GND	Signal Ground
7	PG2	Power Ground Channel 2	23	FREQ	Frequency Pin
8	PG2	Power Ground Channel 2	24	COMP1	Compensation Pin 1
9	HS_DRV2	High Side Gate Drive Channel 2	25	CSN1	Current Sense Negative 1
10	LS_DRV2	Low Side Gate Drive Channel 2	26	CSP1	Current Sense Positive 1
11	SW2	Inductor Connection Channel 2	27	PV1	Input Power Channel 1
12	PV2	Input Power Channel 2	28	PV1	Input Power Channel 1
13	PV2	Input Power Channel 2	29	PV1	Input Power Channel 1
14	PV2	Input Power Channel 2	30	SW1	Inductor Connection Channel 1
15	CSP2	Current Sense Positive 2	31	LS_DRV1	Low Side Gate Drive Channel 1
16	CSN2	Current Sense Negative 2	32	HS_DRV1	High Side Gate Drive Channel 1
	EPAD	Thermal Dissipation Pad			

Typical Application Schematic

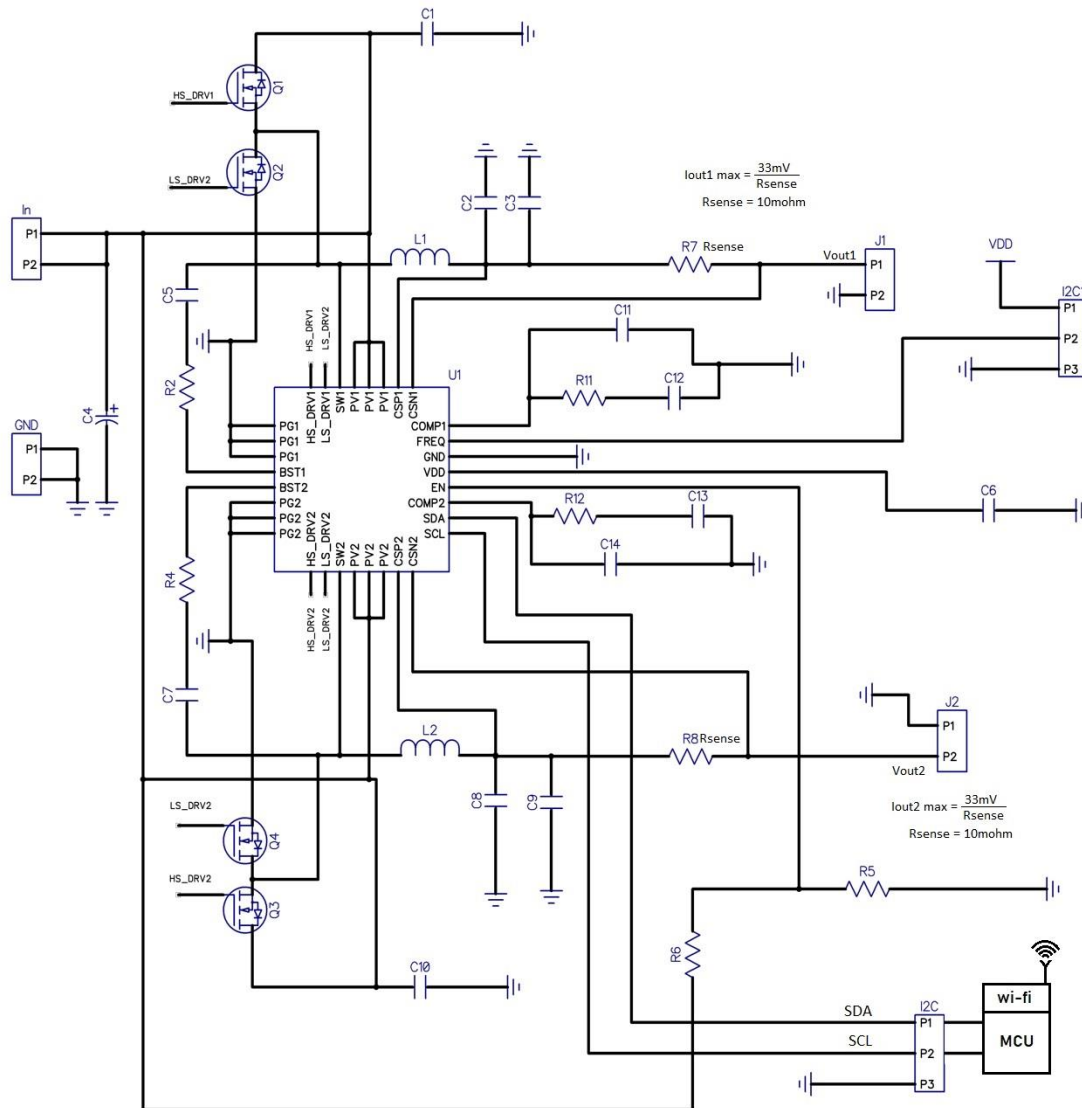
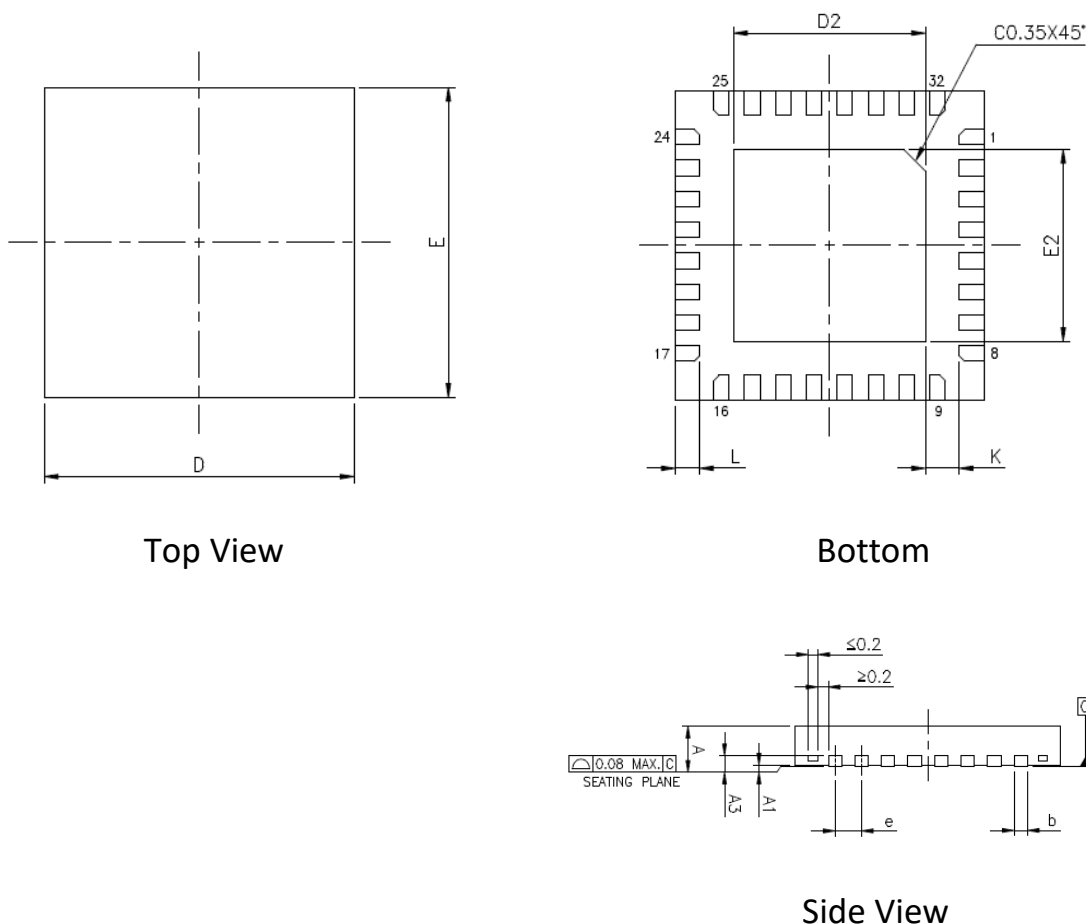

Fig. 4 - HT3328 Typical Application Schematic (Simplified)

Package Outline and Dimensions



Top View

Bottom

Side View

JEDEC OUTLINE	PACKAGE TYPE					
	MO-220			MO-220		
PKG CODE	WQFN(X532)			VQFN(Y532)		
SYMBOLS	MIN.	NOM.	MAX.	MIN.	NOM.	MAX.
A	0.70	0.75	0.80	0.80	0.85	0.90
A1	0.00	0.02	0.05	0.00	0.02	0.05
A3	0.203 REF.			0.203 REF.		
b	0.18	0.25	0.30	0.18	0.25	0.30
D	5.00 BSC			5.00 BSC		
E	5.00 BSC			5.00 BSC		
e	0.50 BSC			0.50 BSC		
L	0.35	0.40	0.45	0.35	0.40	0.45
K	0.20	—	—	0.20	—	—

- NOTES :
1. ALL DIMENSIONS ARE IN MILLIMETERS.
 2. DIMENSION b APPLIES TO METALIZED TERMINAL AND IS MEASURED BETWEEN 0.15mm AND 0.30mm FROM THE TERMINAL TIP. IF THE TERMINAL HAS THE OPTIONAL RADIUS ON THE OTHER END OF THE TERMINAL, THE DIMENSION b SHOULD NOT BE MEASURED IN THAT RADIUS AREA.
 3. BILATERAL COPLANARITY ZONE APPLIES TO THE EXPOSED HEAT SINK SLUG AS WELL AS THE TERMINALS.

Fig. 5 32-pin QFN, 5mm x 5mm, 0.5mm pitch

Appendix

The hex data values for programmable constant voltage (CV). The lowest value of CV (output voltage) may go down to 1.2V, depending on applications. The step size is 100mV.

I2C Data (Hex)	CV (V)	I2C Data (Hex)	CV (V)	I2C Data (Hex)	CV (V)	I2C Data (Hex)	CV (V)	I2C Data (Hex)	CV (V)	I2C Data (Hex)	CV (V)
20	3.2	40	6.4	60	9.6	80	12.8	A0	16.0	C0	19.2
21	3.3	41	6.5	61	9.7	81	12.9	A1	16.1	C1	19.3
22	3.4	42	6.6	62	9.8	82	13.0	A2	16.2	C2	19.4
23	3.5	43	6.7	63	9.9	83	13.1	A3	16.3	C3	19.5
24	3.6	44	6.8	64	10.0	84	13.2	A4	16.4	C4	19.6
25	3.7	45	6.9	65	10.1	85	13.3	A5	16.5	C5	19.7
26	3.8	46	7.0	66	10.2	86	13.4	A6	16.6	C6	19.8
27	3.9	47	7.1	67	10.3	87	13.5	A7	16.7	C7	19.9
28	4.0	48	7.2	68	10.4	88	13.6	A8	16.8	C8	20.0
29	4.1	49	7.3	69	10.5	89	13.7	A9	16.9	C9	20.1
2A	4.2	4A	7.4	6A	10.6	8A	13.8	AA	17.0	CA	20.2
2B	4.3	4B	7.5	6B	10.7	8B	13.9	AB	17.1	CB	20.3
2C	4.4	4C	7.6	6C	10.8	8C	14.0	AC	17.2	CC	20.4
2D	4.5	4D	7.7	6D	10.9	8D	14.1	AD	17.3	CD	20.5
2E	4.6	4E	7.8	6E	11.0	8E	14.2	AE	17.4	CE	20.6
2F	4.7	4F	7.9	6F	11.1	8F	14.3	AF	17.5	CF	20.7
30	4.8	50	8.0	70	11.2	90	14.4	B0	17.6	D0	20.8
31	4.9	51	8.1	71	11.3	91	14.5	B1	17.7	D1	20.9
32	5.0	52	8.2	72	11.4	92	14.6	B2	17.8	D2	21.0
33	5.1	53	8.3	73	11.5	93	14.7	B3	17.9		
34	5.2	54	8.4	74	11.6	94	14.8	B4	18.0		
35	5.3	55	8.5	75	11.7	95	14.9	B5	18.1		
36	5.4	56	8.6	76	11.8	96	15.0	B6	18.2		
37	5.5	57	8.7	77	11.9	97	15.1	B7	18.3		
38	5.6	58	8.8	78	12.0	98	15.2	B8	18.4		
39	5.7	59	8.9	79	12.1	99	15.3	B9	18.5		
3A	5.8	5A	9.0	7A	12.2	9A	15.4	BA	18.6		
3B	5.9	5B	9.1	7B	12.3	9B	15.5	BB	18.7		
3C	6.0	5C	9.2	7C	12.4	9C	15.6	BC	18.8		
3D	6.1	5D	9.3	7D	12.5	9D	15.7	BD	18.9		
3E	6.2	5E	9.4	7E	12.6	9E	15.8	BE	19.0		
3F	6.3	5F	9.5	7F	12.7	9F	15.9	BF	19.1		

The hex data values for programmable current limit (CC). The step size is 100mA. $R_{sense}=10m\Omega$

I2C Data (Hex)	CC (A)	I2C Data (Hex)	CC (A)	I2C Data (Hex)	CC (A)	I2C Data (Hex)	CC (A)	I2C Data (Hex)	CC (A)	I2C Data (Hex)	CC (A)
0	-	7	0.7	E	1.4	15	2.1	1C	2.8	23	3.5
1	0.1	8	0.8	F	1.5	16	2.2	1D	2.9	24	3.6
2	0.2	9	0.9	10	1.6	17	2.3	1E	3.0	25	3.7
3	0.3	A	1.0	11	1.7	18	2.4	1F	3.1	26	3.8
4	0.4	B	1.1	12	1.8	19	2.5	20	3.2	27	3.9
5	0.5	C	1.2	13	1.9	1A	2.6	21	3.3	28	4.0
6	0.6	D	1.3	14	2.0	1B	2.7	22	3.4		

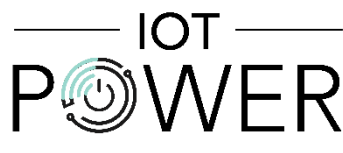

HT3000 Series
Smart Home Connection
At Your Fingertips



Hong Kong Office
Tel: (852) 36195375
Email: sales@hightt.com
URL: <https://hightt.com>
Address:
Unit 713, 7/F, 12W, 12 Science Park West Avenue,
Hong Kong Science Park, Shatin, Hong Kong

微信 WeChat

