

USB Type-C and PD Source Controller

1. FEATURES

- USB PD3.0 and Type-C 1.3
- Support up to Five FPDOS
 - Typical 5V, 9V, 12V, 15V and 20V FPDOS
- Support up to three APDOs
 - Support 5V-Prog, 9V-Prog, 15V-Prog and 20V-Prog
 - 20mV LSB Voltage Regulation and 50mA LSB for Current Regulation
 - Constant power limit
- Support QC2.0/QC3.0, BC1.2 DCP protocols
 - Apple 5V, 2.4A mode
 - BC1.2 DCP mode
 - QC2.0 5V/9V/12V and 20V
 - QC3.0 3.6V~20V continuous model voltage mode with 200mV step adjustment
 - Support Fast Charging Protocol, FCP
 - Support Adaptive Fast Charging, AFC
- Constant Voltage (CV) and Constant Current Limit (CC) Regulation
 - Integrated secondary side compensation circuit, such as TL431
- Built-in VIN and VBUS pins fast discharge scheme
- Small Current Sensing Resistor (5mΩ) for High Efficiency application
- CC1/CC2 Pin Protection up to 28V
- Support cable drop compensation with 0, 50m, 100m/200mΩ selection
- Support Smart Power Derating function at two ports USB application (USB-C or USB-A)
- Integrated VCONN power and eMarker detection
- Built-in adaptive UVP, adaptive OVP, I_OTP, E_OTP, CC_OVP and VCONN_OCP Fault Detections

2. APPLICATIONS

- AC-DC PD Compliant power adapters
- DC-DC Car chargers
- USB-PD converter

3. GENERAL DESCRIPTION

The HT5350 is a highly integrated PD source controller that support USB PD3.0, PD2.0, PPS, QC2.0/3.0, FCP, AFC, BC1.2 DCP etc.

The HT5350 incorporates various protections, such as Under Voltage Protection (UVP), Over Voltage Protection (OVP), Over Current Protection (OCP), CC1 and CC2 Over Voltage Protection (CC_OVP), VCONN Over Current Protection (VCONN_OCP), and internal and external Over Temperature protection (I_OTP and E_OTP). With a 10-bit A/D converter, output voltage, output current, IC internal temperature and external temperature via an NTC resistor can be monitored. The HT5350 provides the smart power derating function for dual-port charger application.

The HT5350 is designed to operate with general ACDC, DCDC controller or I²C interface ACDC, DCDC controller.

4. PART NUMBER INFORMATION

PART NO.	PACKAGE
HT5350	QFN16

5. TYPICAL APPLICATION

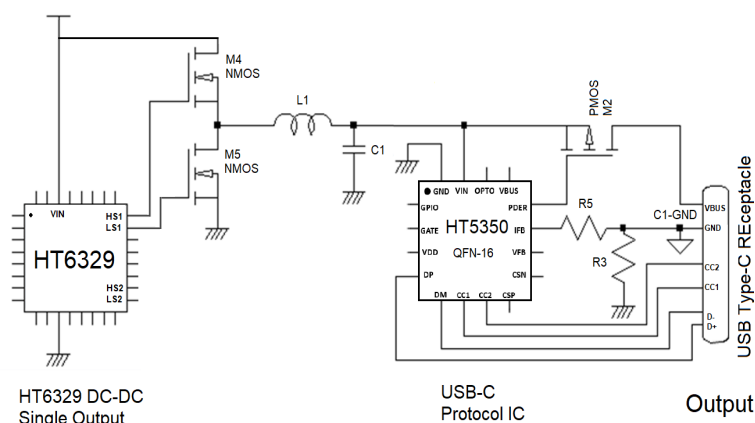

Figure 1. Typical Application Circuit of HT5350